

**INTRODUCTION:**

Parker's logic valves offer system designers a versatile range of screw-in elements that, when used in the proper combinations, can provide flexible design solutions for many common cartridge valve applications. They offer system designers the advantage of applying cartridge valve technology in applications where the flow and pressure conditions may exceed the limits of typical cartridge valves. Logic valves are essentially high flow poppet or spool elements that are controlled by small pilot devices. They can be used to control flow, pressure, or direction, and when applied in the proper arrangements, can perform multi-task control functions. Parker's logic valves offer system designers alternative products that can help reduce the size, cost, and complexity of integrated manifold systems.

**NEW PRODUCTS:**

Parker Logic Valves are offered in two basic categories: Poppet and Spool.

**Poppet Type** - Used for flow switching directional control applications.

**Spool Type** - Used for pressure sensing in modulating applications to regulate flow and pressure.

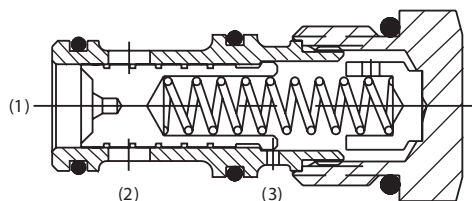
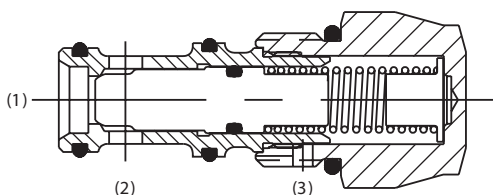

**PRODUCT TYPES / APPLICATIONS**  
**POPPET TYPE**

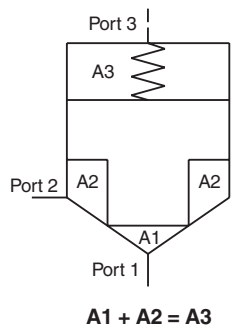

Poppet type logic valves are 3 ported, 2-way on/off valves that switch flow between port 1 and port 2. The poppet's on/off action is operated by controlling pilot oil at port 3 of the valve. A small low flow solenoid or pilot valve is an ideal control for this purpose. Parker offers vent-to-open and pilot-to-close style poppet logic valves.

**Note:** Poppet logic valves are an unbalanced 2:1 ratio poppet design. The opening and closing of the poppet is dependent on the force balances on the areas of the poppet at port 1, port 2, and port 3.

**Vent-to-open logic valves:**

Vent-to-open logic valves are primarily used for uni-directional switching applications. The poppet in the vent-to-open logic valve is spring biased to the closed condition. The pilot oil source that operates the logic element is generated internally by direct pressure from either work port 1 or 2, depending on the option chosen. Venting the pilot oil at port 3 allows the valve to open and pass flow between port 1 and 2 at the bias spring setting. Blocking the pilot at port 3 causes the valve to close. When closed, the 2:1 ratio poppet design provides a positive low leak seal. Because the pilot source is generated internally within the valve, vent-to-open logic valves are best suited for uni-directional applications.

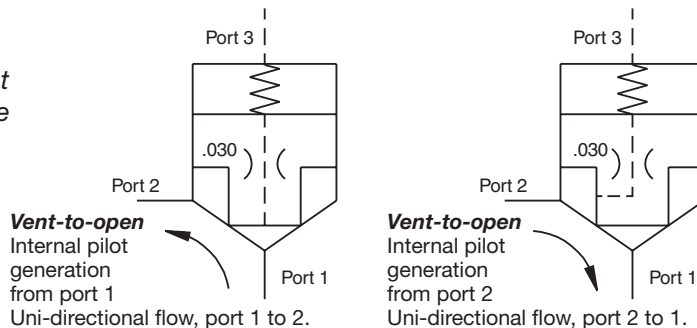

CV
Check Valves
SH
Shuttle Valves
LM
Load/Motor Controls
FC
Flow Controls
PC
Pressure Controls
LE
Logic Elements
DC
Directional Controls
SV
Solenoid Valves
PV
Proportional Valves
CE
Coils & Electronics
BC
Bodies & Cavities
TD
Technical Data

## Technical Tips

### POPPET TYPE *Continued*

#### **Pilot-to-close logic valve:**

Pilot-to-close logic elements are primarily used for bi-directional flow switching applications. The poppet in the pilot-to-close logic valve is spring biased to the closed condition. With no pilot signal at port 3, the valve will open allowing flow in either direction between work ports 1 and 2 once pressure at one of the work ports reaches the biased spring setting. Applying a sufficient externally generated pilot force to port 3 of the valve closes the poppet creating a low leak seal between port 1 and port 2.

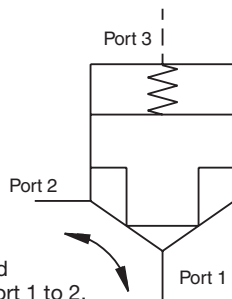

**Pilot-to-close**  
External pilot required  
Bi-directional flow, port 1 to 2.

## Logic Elements

### **2-way, 3-way, and 4-way Directional Control:**

Poppet logic valves are typically used to perform high flow directional switching operations using small low power pilot valves to control the sequence of the directional operation.

- A single logic valve can be used to control 2-way, on/off switching.
- Multiple elements in a bridge arrangement can control 3-way or 4-way directional switching.
- Since each logic valve is individually controlled, the timing, sequence, and overlap of directional functions can be controlled very precisely.
- Uni-directional or bi-directional flow can be achieved, depending on the valve selected.
- Flows in excess of 80 gpm can be controlled through a single logic element, and more than one logic valve can be used in parallel to control flow in excess of the rated flow of a single element.
- Poppet construction provides a low leak directional control.

(See circuit examples on pages LE5-LE6)

### SPOOL TYPE

Spool type logic valves can also be used for directional switching, however, they are typically used in modulating applications to control flow or regulate pressure. Virtually any pressure or flow control function can be achieved with a spool type logic valve including; restrictive or priority flow control, pressure relief, pressure reducing, sequencing, and unloading.

The spools in this category of logic valves are balanced designs; the spool area at the work port (port 1) and the pilot port (port 3) are equal (1:1). The spool is held in a biased condition by a spring. Venting the pilot at port 3 creates an unbalanced condition causing the valve spool to modulate open or close, depending on the valve chosen. This spool design makes the valve vary stable because the forces acting to open and close the valve are in balance.

### **Flow Control / Compensators:**

Parker offers two types of logic valves for flow control functions.

- 1) Normally open spools function as a restrictive type compensator.
- 2) Normally closed spools function as a priority or by-pass compensator.

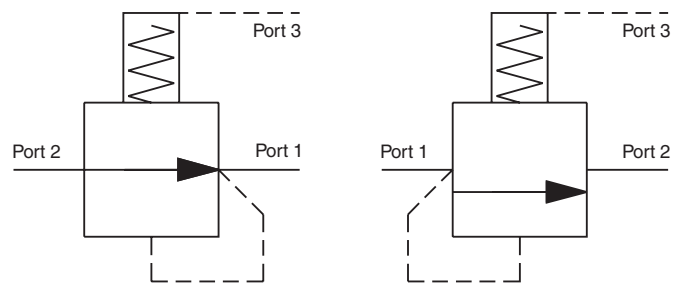

**Normally open spool**

**Normally closed spool**

CV	Check Valves
SH	Shuttle Valves
LM	Load/Motor Controls
FC	Flow Controls
PC	Pressure Controls
LE	Logic Elements
DC	Directional Controls
SV	Solenoid Valves
PV	Proportional Valves
CE	Coils & Electronics
BC	Bodies & Cavities
TD	Technical Data

## Technical Tips

### Restrictive Flow Regulator:

Normally open spool type logic elements can be used with an external orifice or valve as a compensator to regulate flow. Used as restrictive compensator, a normally open spool senses the upstream and downstream pressure across an orifice or valve. The spool modulates closed to maintain a constant pressure drop across the controlled device equal to the bias spring in the logic valve, thus maintaining a constant flow rate regardless of changes in upstream or downstream pressure.

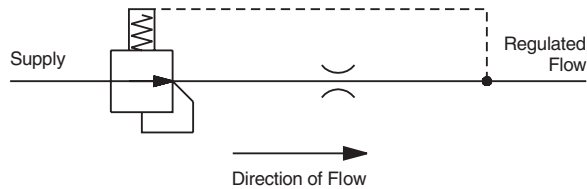

## Logic Elements

### Priority / Bypass Flow Regulator:

A logic valve with a normally closed spool can be used as a priority or by-pass compensator. In this case, the spool modulates open to maintain a constant pressure drop across the controlled orifice or valve, thereby maintaining a constant priority flow regardless of upstream or downstream pressure changes. In a priority arrangement, any oil that doesn't saturate the controlled device is by-passed at load pressure plus the value of the bias spring in the logic valve.

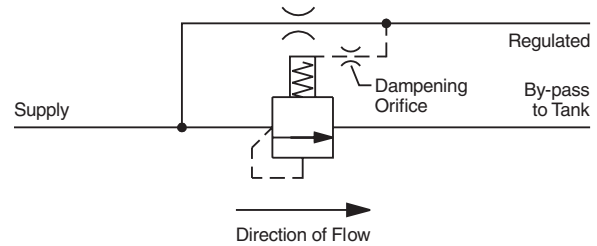

### Pressure Control:

Spool type logic valves can be used as the main stage spool in high flow pressure control applications with the logic valve handling the high flow, and a small pilot valve controlling the action of the logic valve spool. Normally open, and normally closed spool options are available enabling virtually all pressure control functions to be achieved. When used in pressure control applications, the logic valve spool modulates open or closed to maintain the pressure setting of the pilot valve communicated to port 3. Pressure control applications require a pilot connection between the control port (port 1 or 2), and the pilot port (port 3). In order to simplify the design, Parker offers spool type logic valves with internal piloting options that can help minimize the number of connections needed. When used in manifold systems, the internal piloting options help to simplify the manifold design by reducing the number of construction drillings in the block. Multiple functions such as relief, pump unloading, and pressure compensation can be performed with one logic valve by communicating multiple pilot devices to the same logic element.

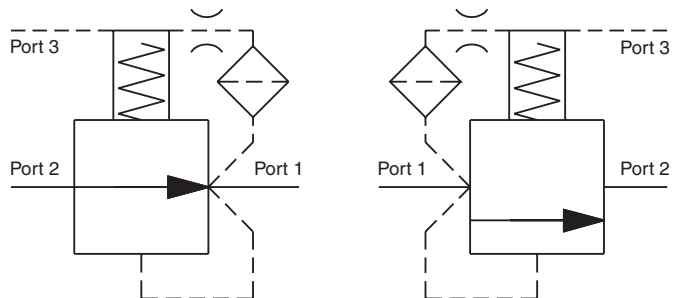

#### Normally open spool

- Pressure Reducing

#### Normally closed spool

- Relief
- Sequence
- Unloading

(See circuit examples on page LE7)

#### Application Note:

This section is as an application guide, and it is intended to illustrate the various ways that logic elements can be used to create a variety of hydraulic control functions. For additional help applying logic valves, contact your Parker Sales Engineer.

CV
Check Valves
SH
Shuttle Valves
LM
Load/Motor Controls
FC
Flow Controls
PC
Pressure Controls
LE
Logic Elements
DC
Directional Controls
SV
Solenoid Valves
PV
Proportional Valves
CE
Coils & Electronics
BC
Bodies & Cavities
TD
Technical Data

**DIRECTIONAL CONTROL EXAMPLES**

**2-position, 2-way normally open example.**  
 Switched by 2-position, 3-way pilot valve and external pilot pressure.

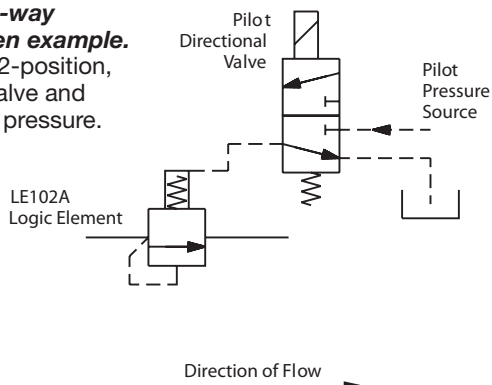

**2-position, 2-way normally open example.**  
 Switched by external pilot pressure and vented through 2-position, 2-way pilot valve.

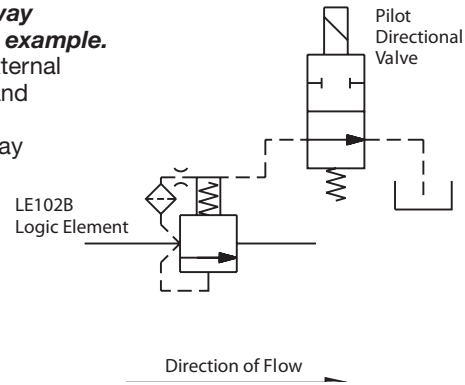

**2-position, 2-way normally open example.**  
 Internal pilot generation.

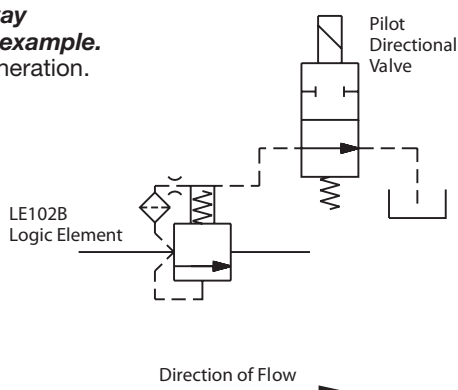

**2-position, 2-way normally open example.**  
 Internal pilot generation.

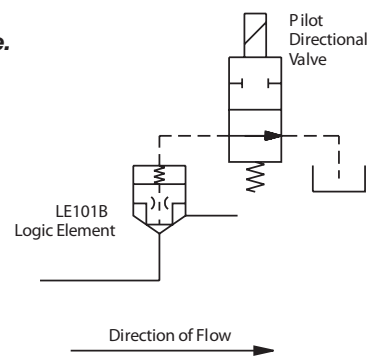

**2-position, 2-way normally open example.**  
 Switched by 2-position, 3-way pilot valve and external pilot.

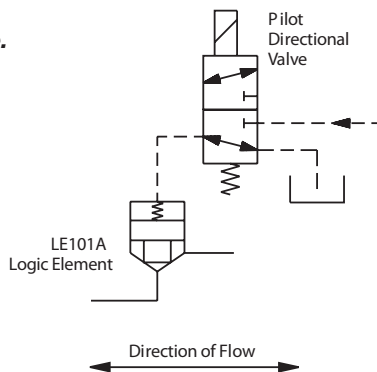

**\*\*SLC1A logic element.**  
 With shuttle-selected pilot supply.

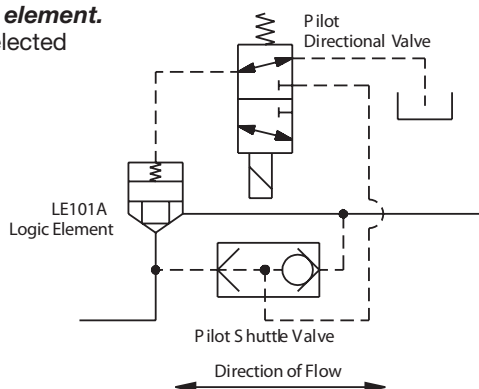

**\*\*SLC1A logic element.**  
 External pilot supply and 2-position, 2-way pilot directional valve.

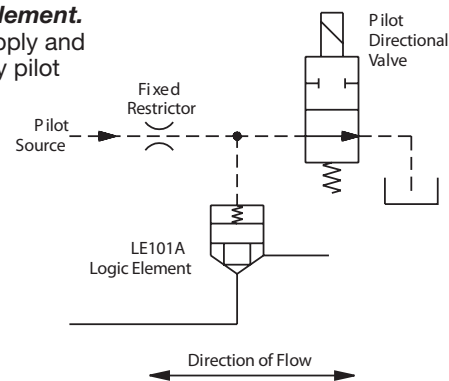

<b>CV</b>
Check Valves
<b>SH</b>
Shuttle Valves
<b>LM</b>
Load/Motor Controls
<b>FC</b>
Flow Controls
<b>PC</b>
Pressure Controls
<b>LE</b>
Logic Elements
<b>DC</b>
Directional Controls
<b>SV</b>
Solenoid Valves
<b>PV</b>
Proportional Valves
<b>CE</b>
Coils & Electronics
<b>BC</b>
Bodies & Cavities
<b>TD</b>
Technical Data

**DIRECTIONAL CONTROL EXAMPLES**

**THREE-WAY BRIDGE CIRCUITS**

*Circuit 1, with LE101A poppet logic element.*

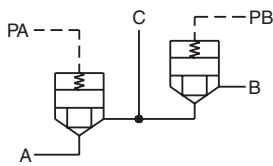

*Circuit 2, with LE102A spool logic element.*

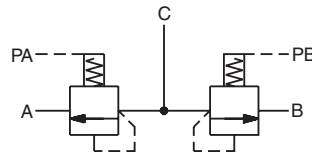

*Circuit 3, with LE102A spool logic element.*

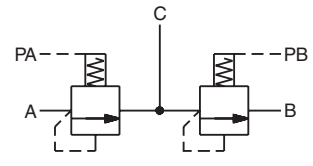

Required Flow Path	Pilot Pressure Applied To		Available From Circuit			Required Flow Path	Pilot Pressure Applied To		Available From Circuit		
	PA	PB	1	2	3		PA	PB	1	2	3
	NO	NO	X	X			NO	YES	X	X	
	YES	NO	X	X	X		NO	YES	X		X

**NOTE:** Pilot pressure must exceed load pressure in order for valve to close.

**FOUR-WAY BRIDGE CIRCUITS**

*Circuit 1, with LE101A poppet logic elements.*

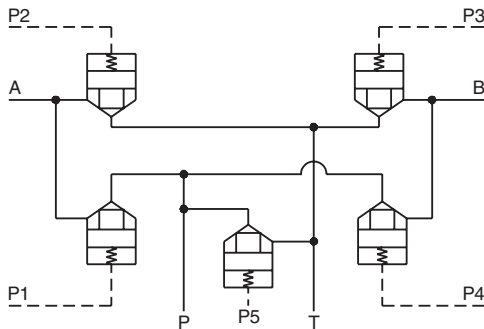

*Circuit 2, with LE102A spool logic elements.*

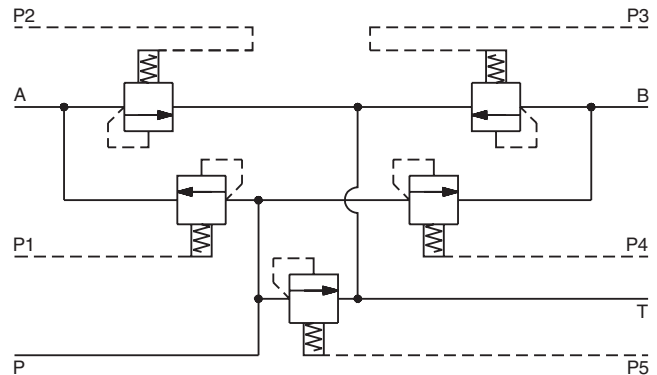

Required Flow Path	Pilot Pressure Applied To					Required Flow Path	Pilot Pressure Applied To					Required Flow Path	Pilot Pressure Applied To				
	P1	P2	P3	P4	P5		P1	P2	P3	P4	P5		P1	P2	P3	P4	P5
	YES	YES	YES	YES	YES		YES	NO	NO	YES	YES		YES	NO	YES	NO	YES
	NO	NO	NO	NO	NO		NO	YES	YES	NO	YES		YES	YES	YES	NO	YES
	YES	YES	NO	NO	NO		YES	YES	NO	YES	YES		YES	NO	YES	YES	YES
	NO	NO	YES	YES	NO		NO	YES	YES	YES	YES						
	YES	YES	YES	YES	NO		NO	YES	NO	YES	YES						

**NOTE:** Pilot pressure must exceed load pressure in order for valve to close.

CV
Check Valves
SH
Shuttle Valves
LM
Load/Motor Controls
FC
Flow Controls
PC
Pressure Controls
LE
Logic Elements
DC
Directional Controls
SV
Solenoid Valves
PV
Proportional Valves
CE
Coils & Electronics
BC
Bodies & Cavities
TD
Technical Data

**FLOW CONTROL EXAMPLES**

**Pressure compensated priority flow control example.**

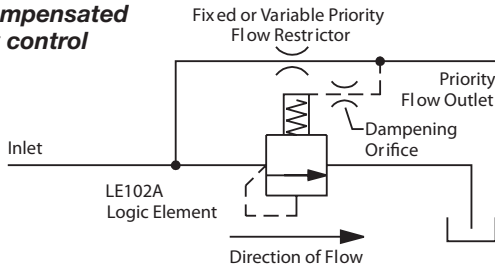

**Load sensing priority flow control example with pressure limiting and unloading.**

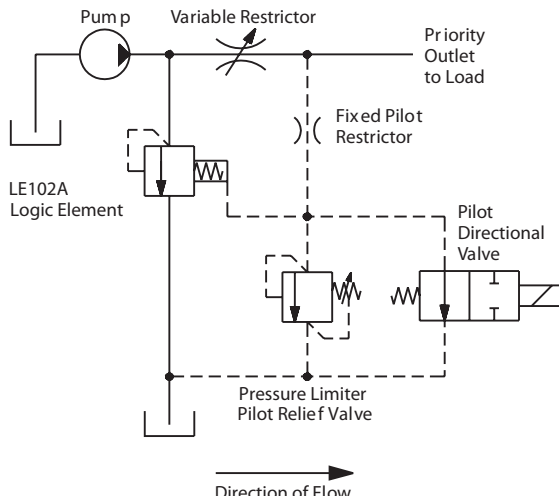

**Pressure compensated restrictive flow control example.**

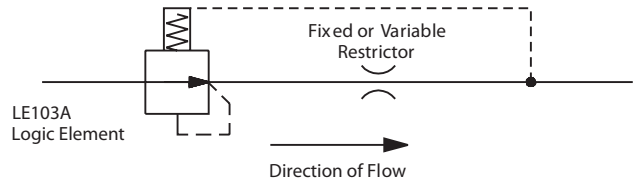

**Load sensing priority flow control example with pressure limiter.**

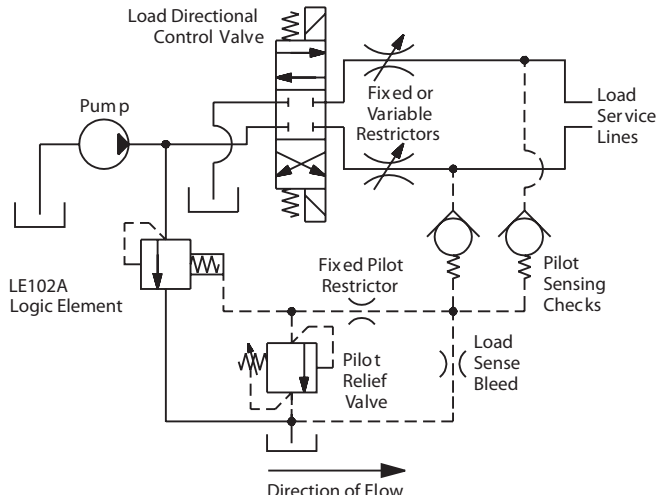

**PRESSURE CONTROL EXAMPLES**

**Pressure relief or sequence example with external pilot supply and pilot relief.**

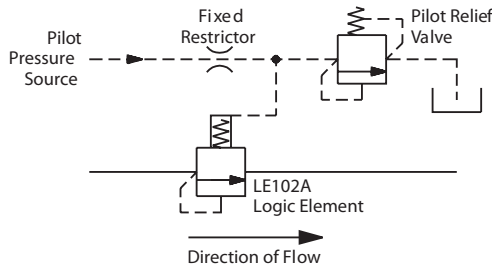

**Pressure reducing example, non-relieving type.**

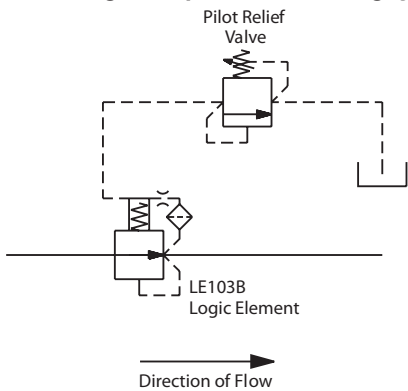

**Pressure relief or sequence example with internal pilot supply and pilot relief.**

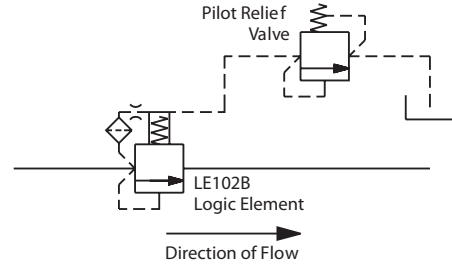

**Pressure reducing-relieving example.**

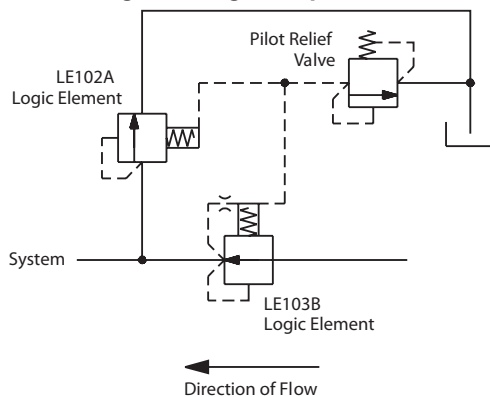

CV
Check Valves
SH
Shuttle Valves
LM
Load/Motor Controls
FC
Flow Controls
PC
Pressure Controls
LE
Logic Elements
DC
Directional Controls
SV
Solenoid Valves
PV
Proportional Valves
CE
Coils & Electronics
BC
Bodies & Cavities
TD
Technical Data